

Optional Particle Coating Door with 150 mm Chuck

Mini Antechamber, made from Stainless Steel
150mm (5.9") diameter x 300mm (11.8") long

Main Antechamber, made from Stainless Steel
360mm (14.2") diameter x 600mm (23.6") long

SECTION A-A

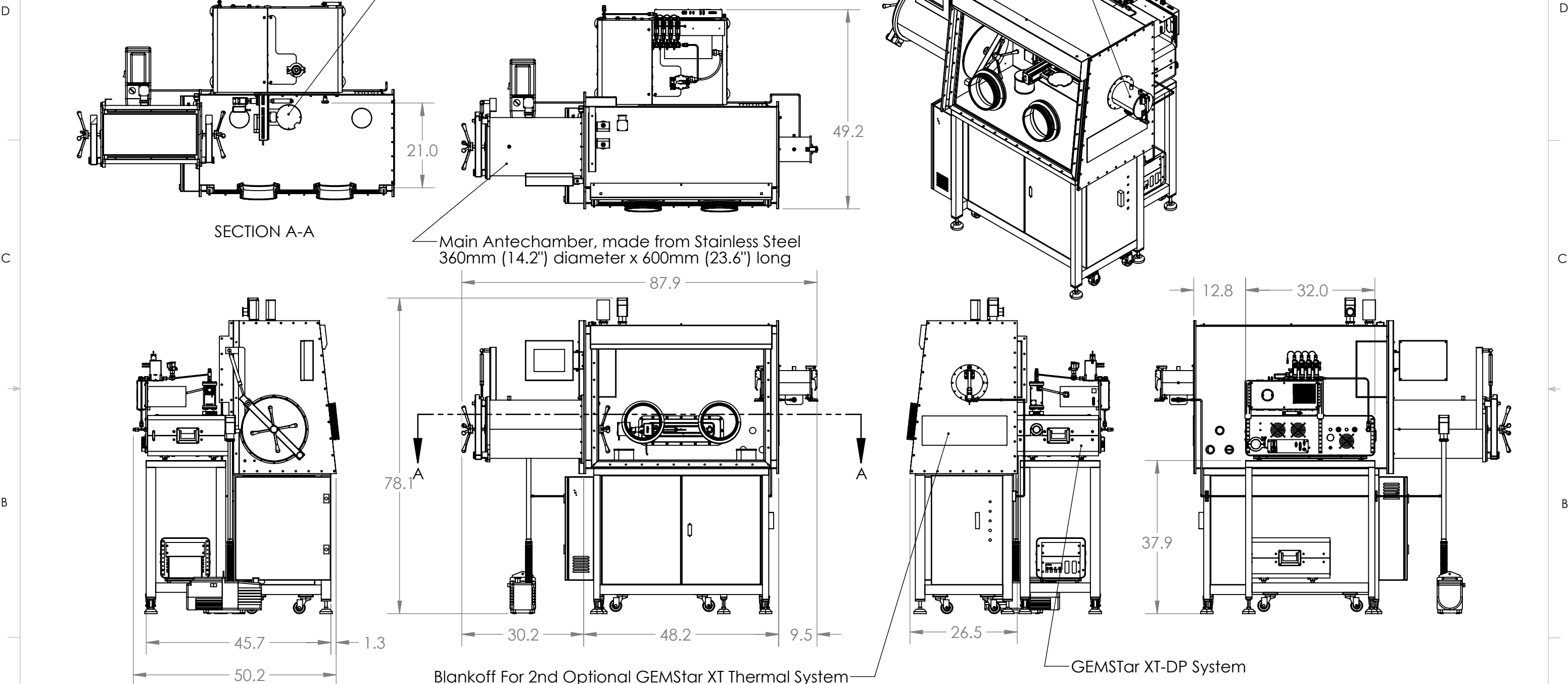

Blankoff For 2nd Optional GEMStar XT Thermal System

GEMStar XT-DP System

UNLESS OTHERWISE SPECIFIED DIMENSIONS ARE IN:	
INCHES TOLERANCES: ANGULAR: MACH ± 0.5° BEND ± 1° X.XXX ± 0.005 X.XX ± 0.010 X.X ± 0.03	(MILLIMETERS) TOLERANCES: ANGULAR: MACH ± 0.5° BEND ± 1° (X.XX ± 0.13) (X.X ± 0.25) (X ± 0.75)

REMOVE BURRS AND BREAK ALL SHARP EDGES
FILLET RADII AND CORNER RADII TO BE .02" (0.5MM)
SURFACE FINISH TO BE 63

NEXT ASSY	USED ON	MATERIAL	NONE
APPLICATION		FINISH	NONE

NAME	DATE
Beaulieu	08/15/18
DRAWN	
CHECKED	
ENG APPR.	

PROPRIETARY AND CONFIDENTIAL

THE INFORMATION CONTAINED IN THIS DRAWING IS THE SOLE PROPERTY OF ARRADIANCE. ANY REPRODUCTION IN PART OR AS A WHOLE WITHOUT THE WRITTEN PERMISSION OF ARRADIANCE IS PROHIBITED.

ARRADIANCE
142 NORTH RD, SUDBURY, MA 01776

TITLE:
GEMStar XT-P With One Station Glovebox

SIZE	DWG. NO.	REV
B	ARR-08.910	0

SCALE: 1:24 WEIGHT: SHEET 1 OF 1

8 7 6 5 4 3 2 1

D

C

B

A

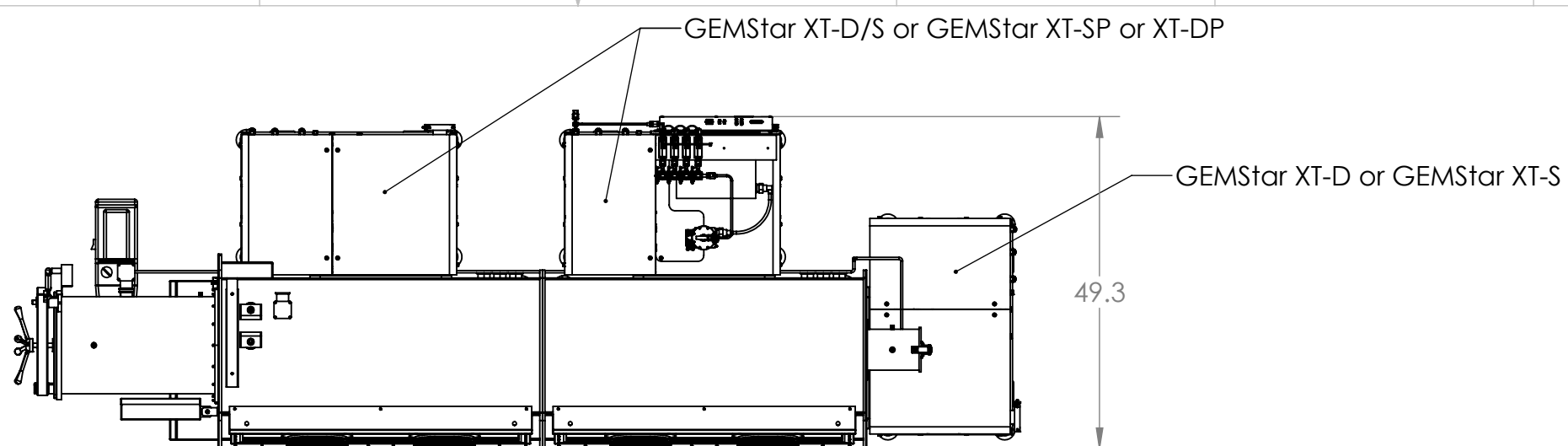

Main Antechamber, made from Stainless Steel
360mm (14.2") diameter x 600mm (23.6") long

Mini Antechamber, made from Stainless Steel
150mm (5.9") diameter x 300mm (11.8") long

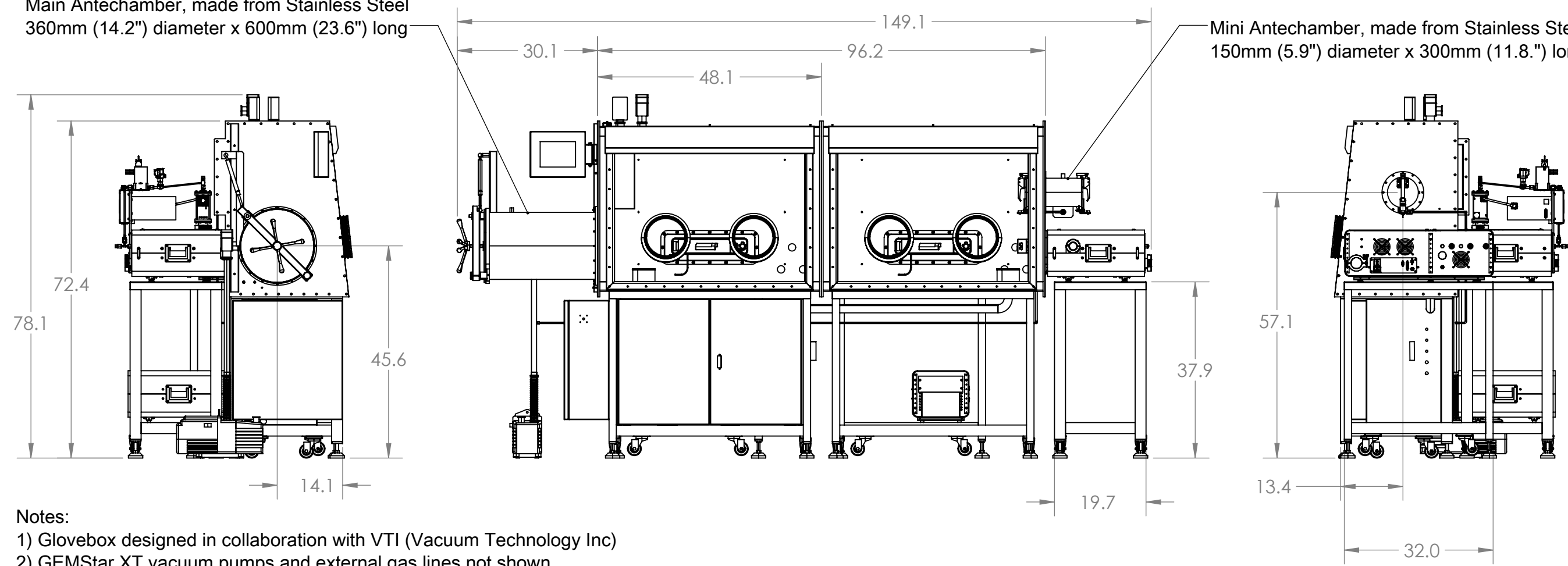

- Notes:
 1) Glovebox designed in collaboration with VTI (Vacuum Technology Inc)
 2) GEMStar XT vacuum pumps and external gas lines not shown

		UNLESS OTHERWISE SPECIFIED DIMENSIONS ARE IN:		NAME	DATE	ARRADIANCE 142 NORTH RD, SUDBURY, MA 01776 TITLE: GLOVEBOX SYSTEM, 2 STATION 3 GEMSTAR SYSTEMS		
		INCHES TOLERANCES: ANGULAR: MACH ± 0.5° BEND ± 1° X.XXX ± 0.005 X.XX ± 0.010 X.X ± 0.03		DRAWN	07/23/18			
		(MILLIMETERS) TOLERANCES: ANGULAR: MACH ± 0.5° BEND ± 1° (X.XX ± 0.13) (X.X ± 0.25) (X ± 0.75)		CHECKED				
		REMOVE BURRS AND BREAK ALL SHARP EDGES FILLET RADII AND CORNER RADII TO BE .02" (0.5MM) SURFACE FINISH TO BE 63		ENG APPR.				
NEXT ASSY	USED ON	MATERIAL	NONE	PROPRIETARY AND CONFIDENTIAL THE INFORMATION CONTAINED IN THIS DRAWING IS THE SOLE PROPERTY OF ARRADIANCE. ANY REPRODUCTION IN PART OR AS A WHOLE WITHOUT THE WRITTEN PERMISSION OF ARRADIANCE IS PROHIBITED.		SIZE	DWG. NO.	REV
APPLICATION		FINISH	NONE			B	ARR-08.885	0
						SCALE: 1:24	WEIGHT:	SHEET 1 OF 1

8 7 6 5 4 3 2 1